

Earth-Rite II Sun Shield

Designed for operating environments subject to intense sunlight, the ERII Sun Shield prevents direct sunlight hitting the indicators on the **Earth-Rite RTR** and **Earth-Rite PLUS** static grounding systems.

The Sun Shield casts a shadow over the indicators during peak sun light hours so that operators can easily view the ground status indicators.

The shield is constructed from stainless steel and can be fitted to any installation in a matter of minutes.



Ground status indicators showing positive grounding of road tanker truck

Ordering Code: ER2/SH

There must be a 40 mm (1.6 in.) gap between the top of the enclosure lid and the inside face of the sun shield.

All holes 7 mm (0.28 in.) diameter.

Ground Sun Shield.

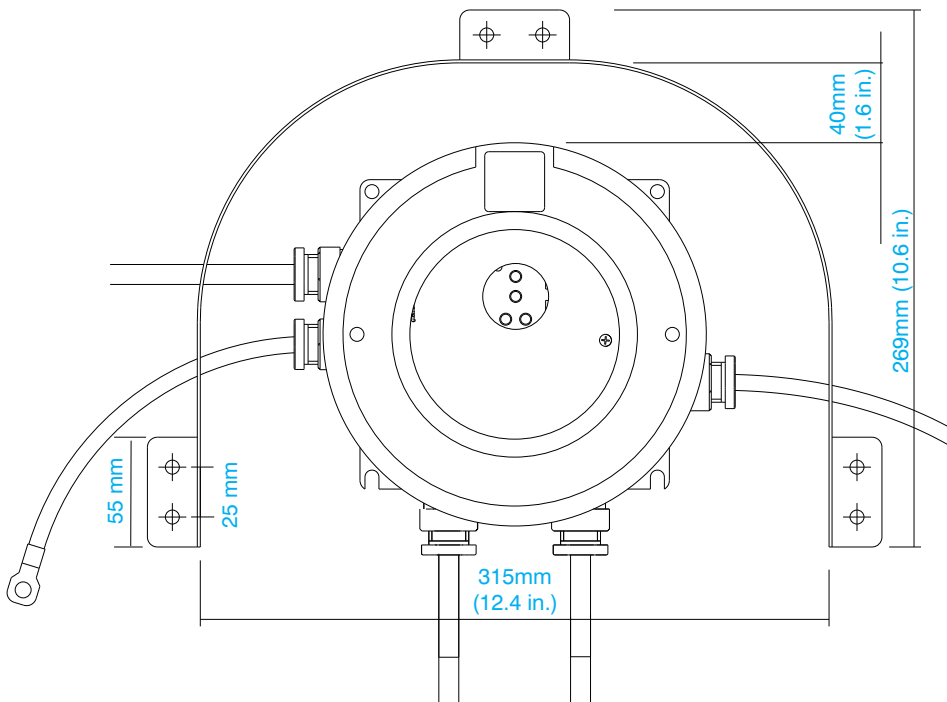

Newson Gale | For over 25 years Newson Gale has been supplying the chemical and processing industry worldwide with its market leading range of static control products ensuring people and plant are protected from static related fires and explosions.